

# A38E

## ELECTRIC ARTICULATED BOOM LIFT



- Popular electric articulated boom lift
- Lightweight, durable and reliable
- Smooth, easy to use controls
- Compact chassis for excellent maneuverability
- Suitable for indoor & outdoor use



**snorkel**<sup>TM</sup>

[www.snorkellifts.com](http://www.snorkellifts.com)

# ELECTRIC ARTICULATED BOOM LIFT

# A38E

## DIMENSIONS A38E

Max. working height	43 ft 7 in
Max. platform height (A)	37 ft 7 in
Max. horizontal reach	20 ft
Clearance height at max. outreach	17 ft 9 in
Platform size (inside) (ExF)	27.1 in x 43.7 in
Overall width (B)	4 ft 11 in
Overall length (C)	13 ft 4.8 in
Stowed height (D)	6 ft 8 in
Ground clearance	4.7 in

## PERFORMANCE

Platform capacity (SWL)	475 lbs
Max. drive height	37 ft 7 in
Max. wind speed	28 mph
Max. drive speed (stowed)	2.5 mph
Max. drive speed (elevated)	0.4 mph
Platform rotation	90°
Superstructure rotation	360° non continuous
Tailswing (riser boom elevated)	0 in
Tailswing (riser boom stowed)	55 in
Raise/lower time	83/68 sec
Gradeability	36%
Inside turning radius	3 ft 8 in
Outside turning radius	7 ft 10 in
Controls	proportional
Drive system	direct drive DC
Tires	22 x 9 16 non-marking rubber

## POWER

Power source	8 x 6V, 220Ah batteries
Battery charger	100-200V/15A

## WEIGHT

Weight	8,554 lbs
--------	-----------

## WORKING ENVELOPE

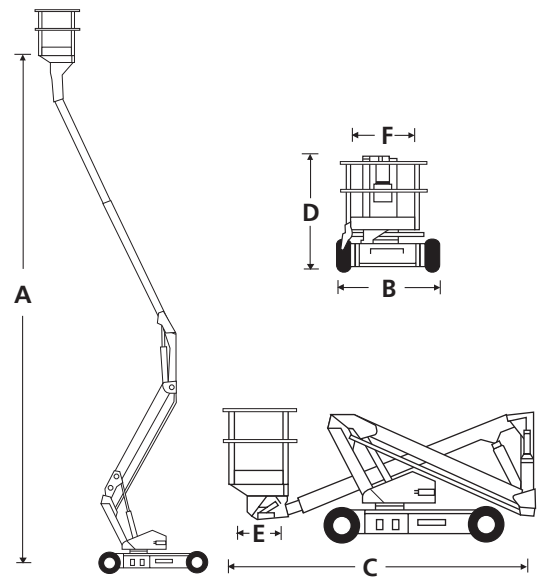
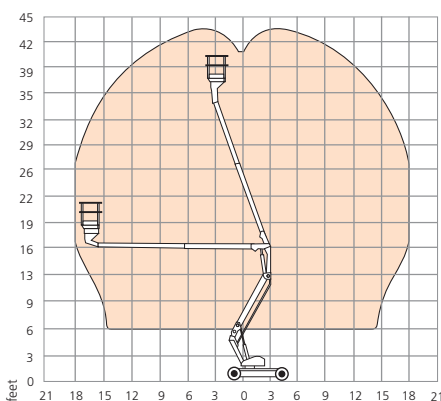

## STANDARD FEATURES

- Snorkel Guard™ secondary guarding system
- Proportional controls
- Hydraulic platform rotation
- Minimal front boom overhang
- Ultra-tight inside turning radius
- 3.5° tilt alarm
- Direct DC drive
- Non-marking tires
- Platform overload system
- Integrated battery charger 90-240V 25A 50/60Hz
- Hour meter & on-board diagnostics display
- Horn
- Flashing amber light
- Drive motion alarm
- Power line to platform
- 2 year parts & labor, 5 year structural warranty
- ANSI compliant

## OPTIONS

- Special paint colors
- Environmental hydraulic oil
- Snorkel OnSite™ telematics

**snorkel** [www.snorkellifts.com](http://www.snorkellifts.com)

P.O. Box 1160  
 St. Joseph, MO 64502-1160, USA  
 Tel: 1 (785) 989-3000  
 Toll-free: 1 (800) 255-0317  
 Fax: 1 (785) 989-3070  
 Email: sales.usa@snorkellifts.com